

IMN TCMA INOX

MAGNETIC LEVEL SWITCH

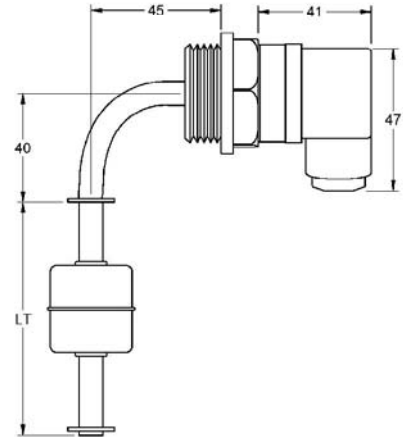

General	Operating principle	The IMN level magnetic sensors are based on the action of a reed switch located inside the tube, which is activated by a magnet housed inside the float and moves due to the thrust of the liquid.	
	Application	<ul style="list-style-type: none"> · For the detection of one or more points in liquid level. · Used in maneuvers for filling, emptying, overflow alarm, etc. 	
	Manufacturing	Are customized to suit the installation conditions.	
Housing	Electrical connection	DIN43650 connector	
	Protection	IP 65	
	Temperature (T _a)	-20..+90 °C	
	Cable gland	PG 9	
	Ø Cable hose (mm)	6..8 mm	
Body	Guide tube	SS AISI316 (1.4401). Ø8 mm	
	Length	50..3500 mm	
	Temperature	-40..+125 °C	
	Mounting position	Bent in 90° elbow	
Process connection	Thread	1" G	1"1/4 G
	Material	SS AISI316 (1.4401)	
	LR (mm)	16	17
	LCP (mm)	15	
	e/c (mm)	32	45
	Be tempted to float is narrower than the width of thread		
Floats	Model	FCI601M09	
	Material	SS AISI316L (1.4404)	
	Dimension (mm)	Ø 29x32	
	Pressure (kg/cm ²)	15	
	Density (g/cm ³)	e > 0,71	
	FS / FH (mm)	9,3 / 22,7	
Contacts	Nr. of contacts	1..3	
	Class	NO: 40 WVA / 230 VAC-2A NC-NO/NC: 20 WVA / 150 VAC-1A	
	Distance between them	> 40 mm	
Protection	Standard	Normal execution without inner filling. Applicable to most applications.	
	Protected	Anti-condensation effect. In installations where there are large temperature differentials.	
	Insulated	Filled with epoxy resin. Establishing a higher degree of tightness.	

How to determine the sensor settings

Determine the total length according to the characteristics of the shell and the liquid level to be controlled.

According to the maneuver you wish to perform, determine the amount, location and type of contacts.
Use the table below to define these characteristics.

Contacts: To set the type of contact (NO, NC, NONC) should be without the presence of the float. For example, if you want the lower end of the sensor contact opens when the tank runs out of fluid, seek an NC contact for the position.

Direction of action (↑ ↓): Set the direction of action of the float (the filling or emptying) allows more precise adjustment of the position of the contacts to the point of desired performance.

Electrical connection: If not otherwise specified explicitly, provide a common connection to all the contacts and an active connection for each of them, according to the diagram below.

Additional floats: The sensor comes equipped by default with a single float, the lower stop and if required, the upper stop. Can request as many additional floats as many contacts as necessary.

Conditions of work: Check that the conditions of pressure, temperature and density of your system match those offered by the model chosen. If you have questions regarding the behavior of materials in contact with the liquid you want to control, see chemical resistance chart on our website.

Apart from the possibilities listed here, there are others such as other floats, various electrical connections, etc..
For other connectivity options and combination of floats and contacts, see our document "Connections for Switches Magnetic Level" you will find on the "Utilities / Tables" our website.

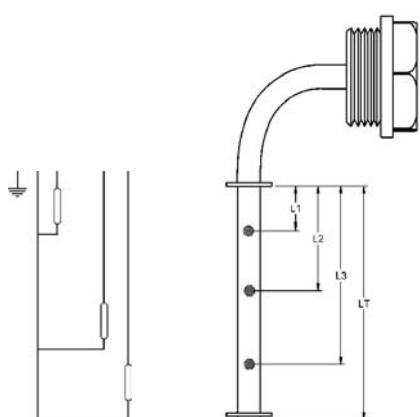

Basic electric connection

	mm	NO	NC	NONC	↑	↓	Stop
L1							
L2							
L3							
LT							

Use this document to define the data of sensor and attach it at the time of ordering.
Specify in mm. total length of the sensor.

Specify in mm. the position of each of the contacts used in your application.

Place an "X" the type and direction of action of each contact.
In the composition table references check boxes next to the selected features.

REFERENCE	VERSION	PROCESS	FLOAT	TOTAL LENGTH	N° CONTACTS	N° FLOATS
IMN TCMA INOX	<input type="checkbox"/> V1 Standard	<input type="checkbox"/> P06 1" G	<input type="checkbox"/> F13 FCI601M09	L 50..1000 mm	<input type="checkbox"/> C1 1 contact	<input type="checkbox"/> N1 1 float
	<input type="checkbox"/> V2 Protected	<input type="checkbox"/> P07 1"1/4 G			<input type="checkbox"/> C2 2 contacts	<input type="checkbox"/> N2 2 floats
	<input type="checkbox"/> V3 Insulated				<input type="checkbox"/> C3 3 contacts	

To compose a reference, select an option from each of the columns. Example: IMN TCMA INOX V1 P06 F13 L500 C1 N1

Advice installation	Installation in areas with turbulences
<p>If the tank is metal walls, the probe will separate from them at least 100 mm.</p>	<p>Place the sensor as far as possible from areas of turbulence.</p>
<p>The maximum slope should be ±15°</p>	<p>Still pipe. Protects the race of the float of the turbulence.</p>
	<p>Separating wall or discouragement.</p> <p>PSIA, DSIA relay: Differential control of max. and min. by timing.</p>

ELECTRICAL CONNECTION EXAMPLES

1 CONTACT

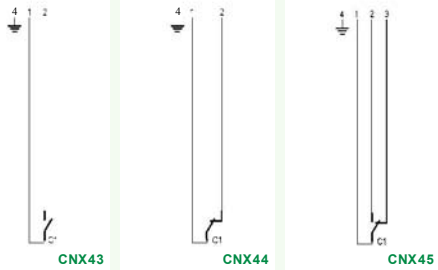

2 CONTACTS

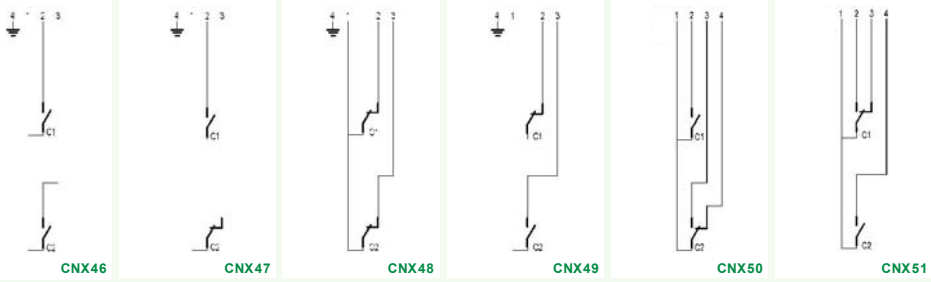

3 CONTACTS

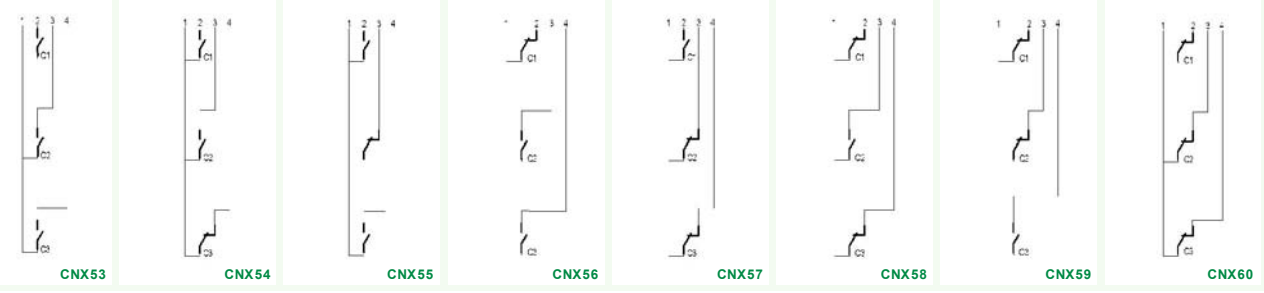

CONTROL TO ONE MAXIMUM OR MINIMUM LEVEL

1 CONTACT

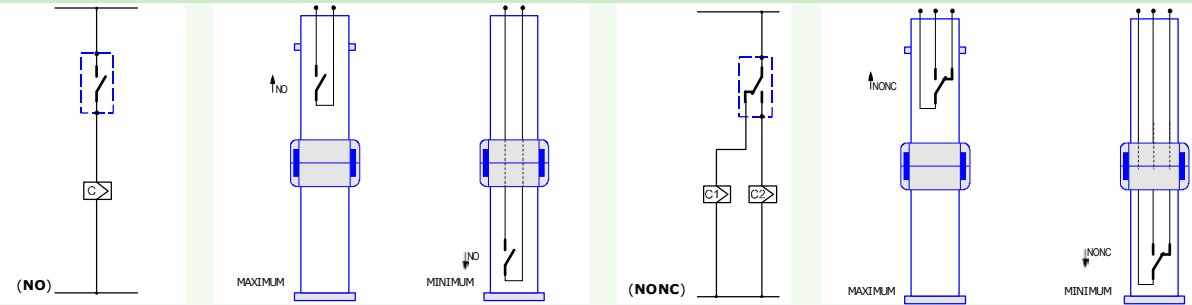

2 CONTACTS

START-STOP WITH INTERLOCKING

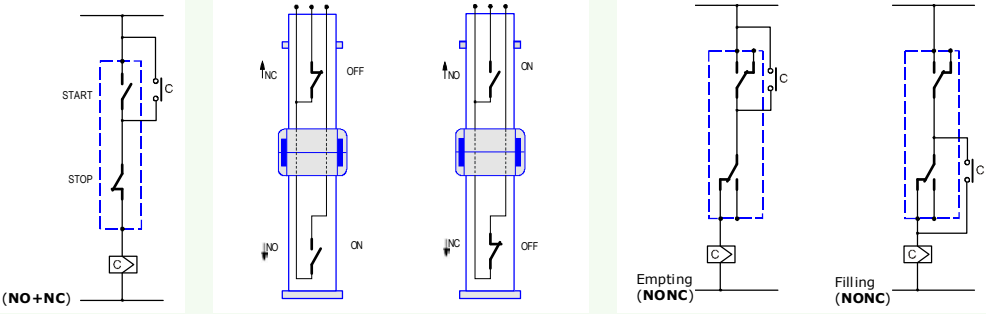

3 CONTACTS

START-STOP EMPTYING + ALARM TO MINIMUM LEVEL

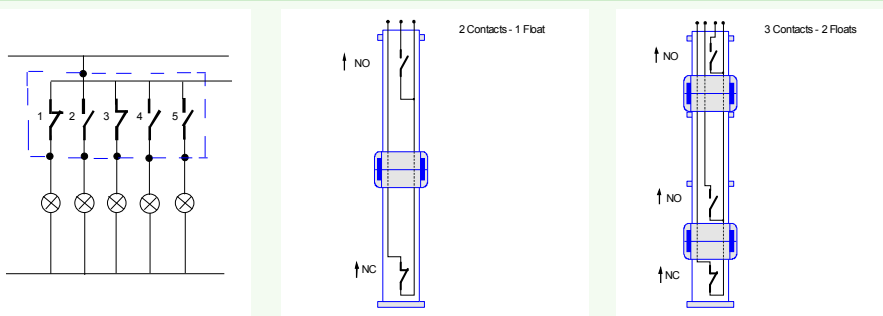

More related information in "Utilities / Tables" on our website (www.disibeint.com)