



Application

Operating principle	IMN level switches are used for the detection and control of one or more level points in liquids, whether conductive or not. They can be used in many types of tanks, cisterns, tanks.
Application	<ul style="list-style-type: none"> For the detection of a single level point in liquids. Used in filling, emptying, overflow alarm, etc.

Constructive features

Process connection	Thread 1/2" NPT
Body material	Satinless steel AISI304L (1.4301)
Operating temperature	-30 .. +125 °C
Protection	<ul style="list-style-type: none"> IP68 in the submerged part IP67 on the outside

Float

Material	Satinless steel AISI304L (1.4301)
Operating pressure	5 kg/cm ²
Density	0,7 g/cm ³
Dimensions	Ø17 x 56 mm

Electrical data

Contact type	Reed switch, normally opened. By reversing the float position, the contact can be NO or NC.
Max contact power	10 W
Max switch voltage	230 VAC/VDC
Min break down voltage	150 VCC
Max switch current	DC 0.5A
Max carry current	1 A
Max contact resistance	100 mohm
Min insulation resistance	109 ohm

Situation

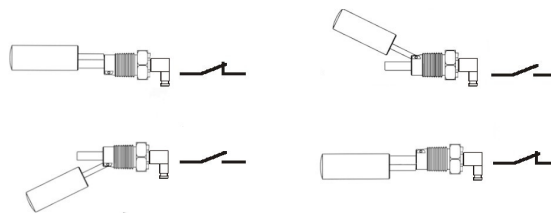

Electrical wiring

Type	DIN43650 Mini connector
Connection	

The complete connector assembly, male and female, is supplied.

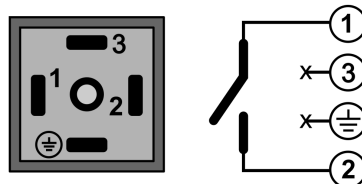

Example of installation

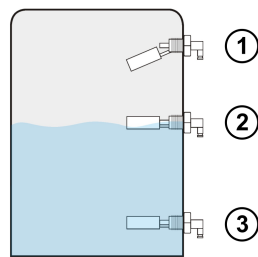

- 1 - Maximum level alarm
- 2 - Maximum level
- 3 - Minimum level

Dimensions

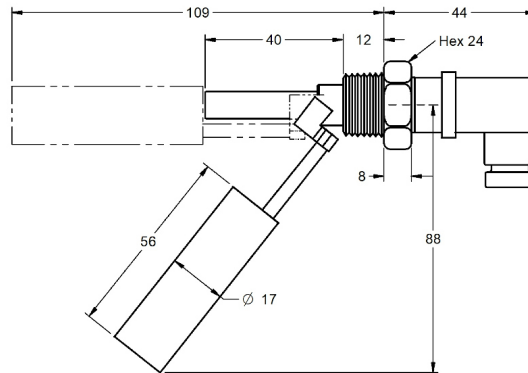

Installation tips

- Shock can alter the characteristics of the sensor.
- Excessive mounting tilt can cause malfunction.
- Vibrations or ripples can cause an unexpected actuation of the contact.
- Use the load appropriate to the load capacity of the contact.
- Keep the sensor away from magnetic fields to avoid false contact operations.